

## BRIDGE FOOTPRINT MEASUREMENTS

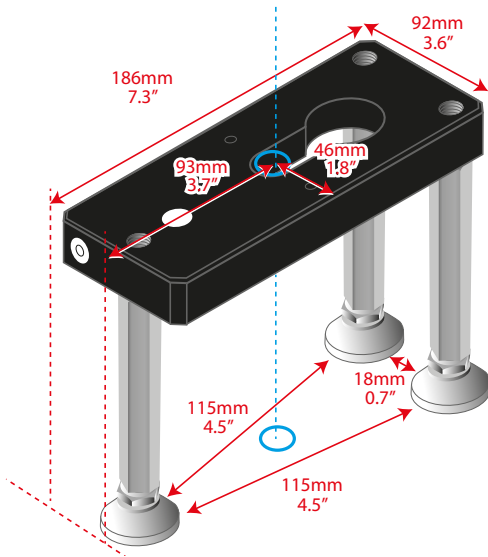

For example:

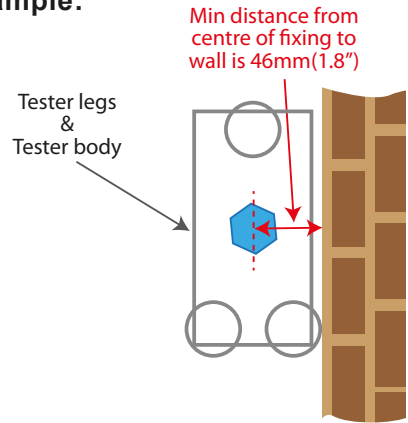

### Bluetooth<sup>®</sup> DIGITAL



The 2000 Model gauge can be upgraded to a detachable 30kN digital gauge with Bluetooth capability offering a variety of additional benefits.

- Results are visual and recorded with time, date and GPS location
- Reports can be provided electronically onsite direct from Android or Apple device - saving time and increasing productivity
- Force displacement option for increased data accuracy

